

Data Sheet



Article number: 2308051572

Description: E+G Index plunger
PMT.100-SST-6-M12x1.5-AK

Measures

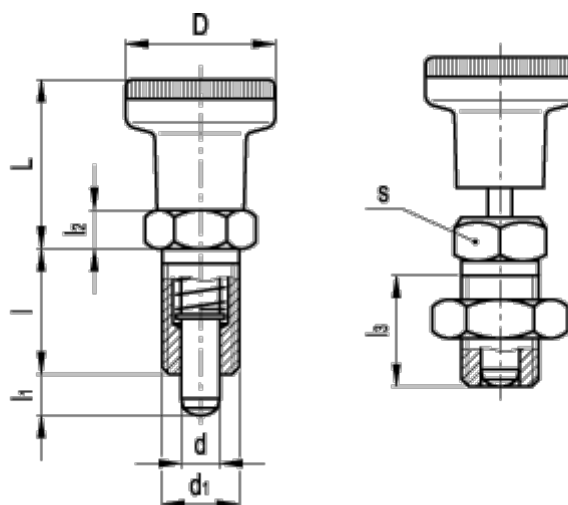

Code = PMT.100-6-M12x1,5-SST-AK

D = 25

d = 6

d1 = M12x1.5

l = 20

L = 28.5

l1 = 6

l2 = 6

l3 = 17

Max. axial load (N) = 21

s = 14